

6 | 5 | 4 | 3 | 2 | 1

Load capacity on the beam is 1250 kN
 Pushing force is 150 kN at 130 bar
 Pulling force is 114 kN at 130 bar
 Stroke 600mm

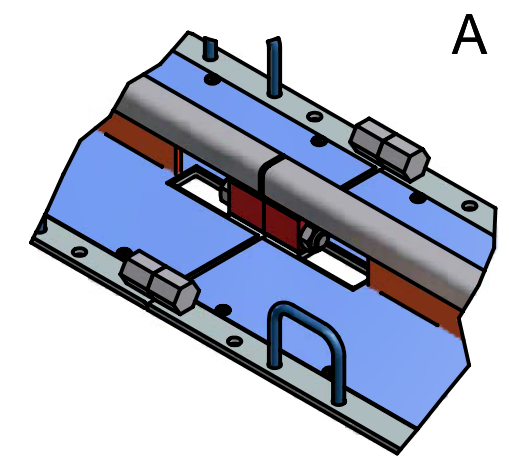

See drawing 02859.01.02.00
 See drawing 02859.01.01.00
 See drawing 02859.11.01.00
 See drawing 02859.01.03.00

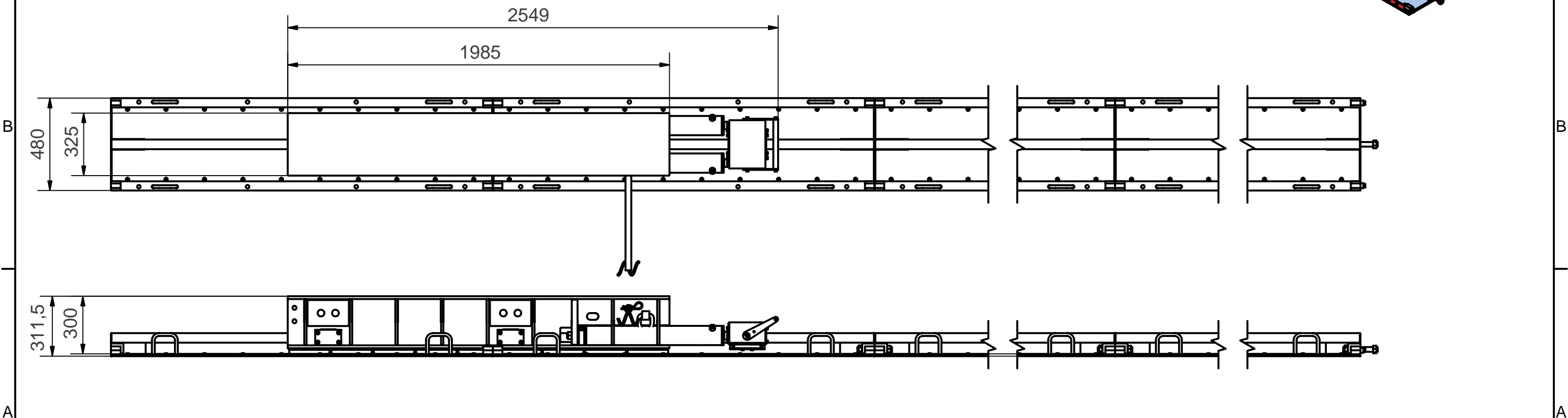
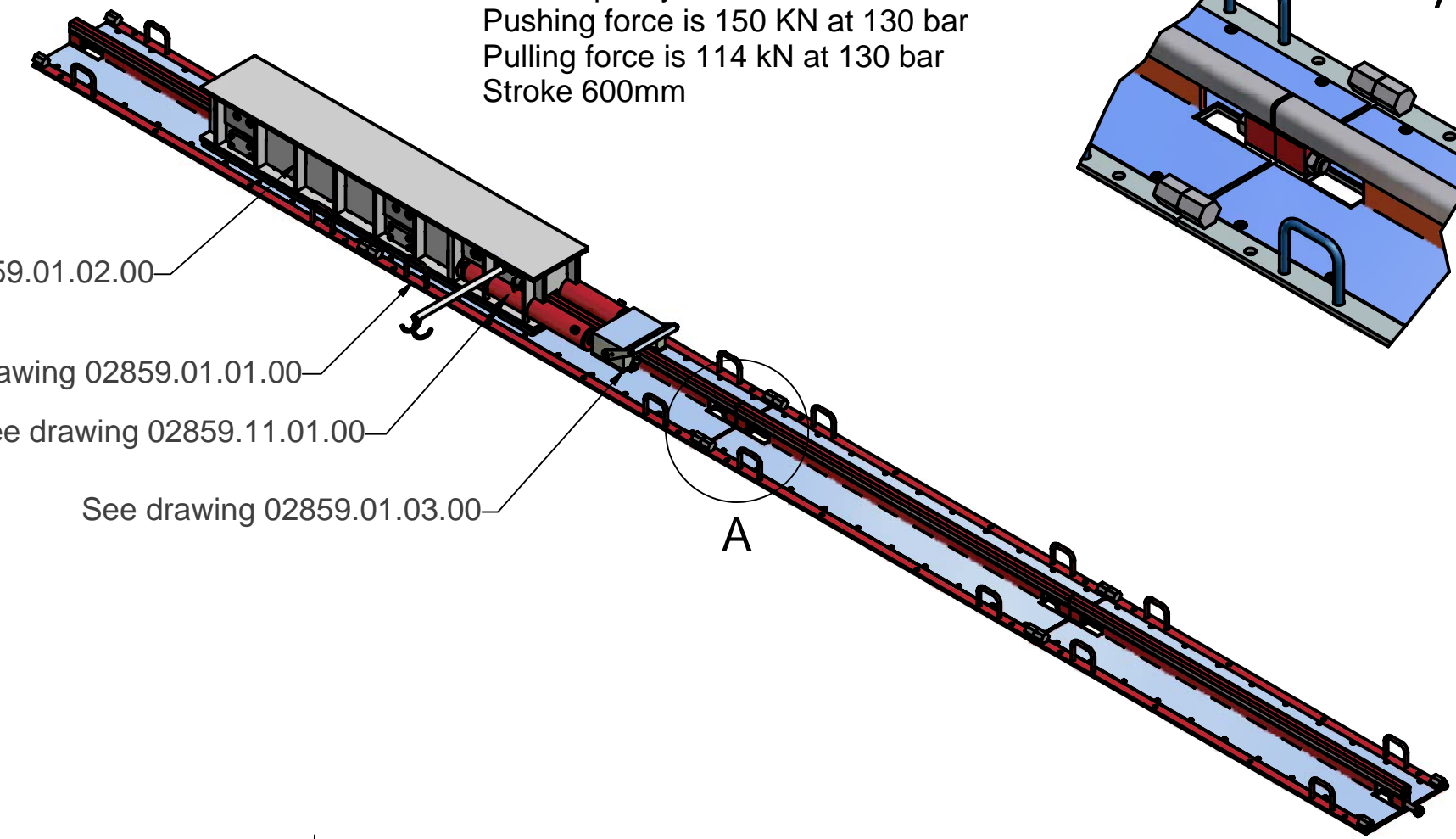

DRAWN: W.t.V.	MASS:	MATERIAL:	REMOVE BURS OF INTERSECTING HOLES. BREAK SHARP EDGES	TOLERANCE UNLESS OTHERWISE STATED: ANGLE: ±0.5° LINEAR: ±0.5
DATE: 13-4-2007	SCALE: 1 : 20	APPROVED:	ROUGHNESS OVERALL: 3.2	PART NAME: Skidding System 125 Te (m)
OPAALSTRAAT 44, 7554 TS HENGELO HOLLAND PO BOX 421, 7550 AK HENGELO HOLLAND TELEPHONE 074-2422045 FACSIMILE 074-2430338 E-MAIL: INFO@HYDROSPEX.NL HYDROSPEX COPYRIGHTS RESERVED			DRAW. NO.: 02859.01.00.00	REV.: FROM: A3

6 | 5 | 4 | 3 | 2 | 1