

An diesen Auflagerstellen sind Antirutschmatten mit einem Reibwert von 0,6 untergelegt.
ANTI Rubber mats $\mu=0,6$

Zurrketten je 10 T chains, each 10 T

An diesen Auflagerstellen sind Antirutschmatten mit einem Reibwert von 0,6 untergelegt.
ANTI Rubber mats $\mu=0,6$

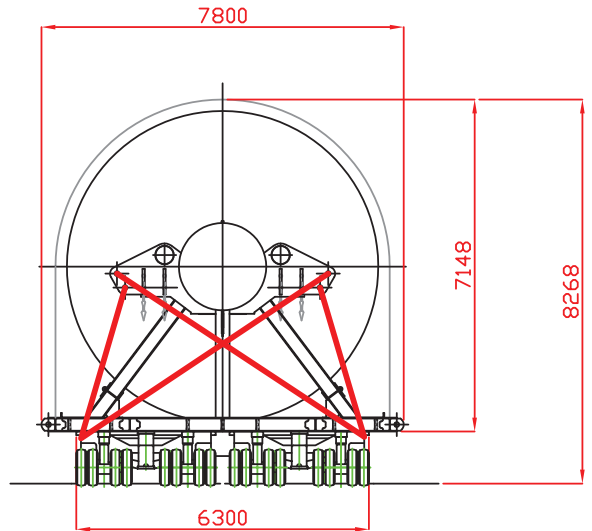
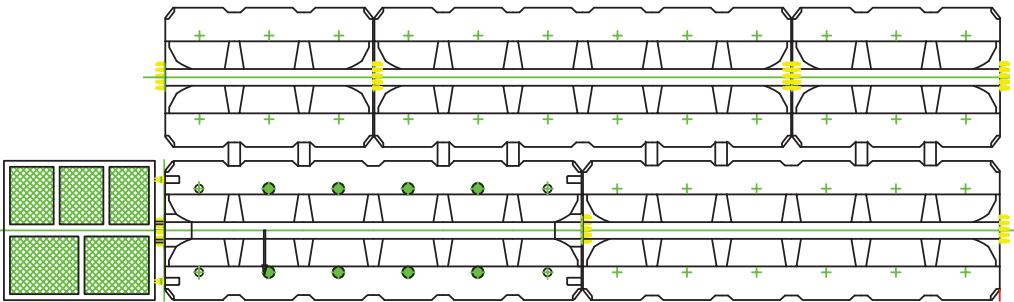
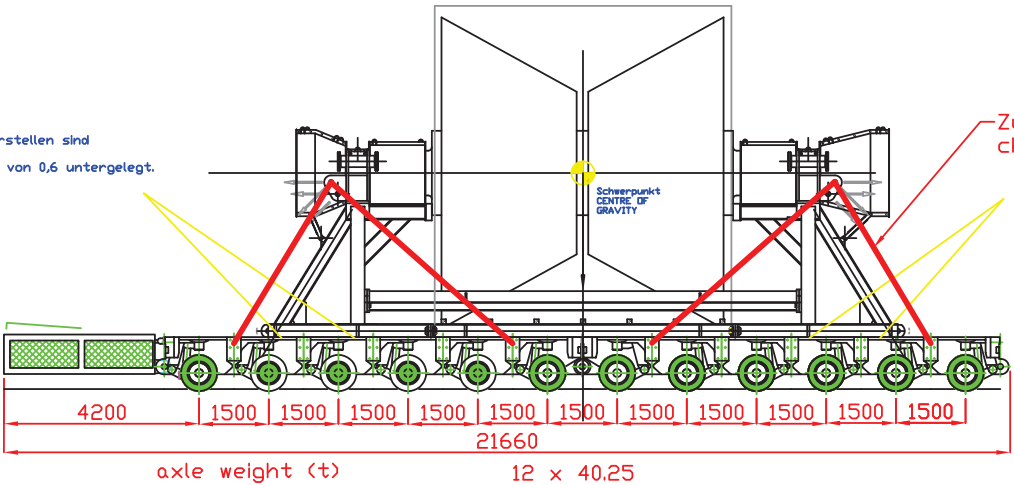

| | loaded | empty | | | | | | |
|--|--|----------------------|------|----------------------|--------|----------|---|--|
| total length (m) | 21.7 | 21.70 | | | | | | |
| total length incl. pushing truck (m) | - | - | | | | | | |
| total width (m) | 7.80 | 6.30 | | | | | | |
| total height (m) | 8.27 (8.15) | 1.12 | | | | | | |
| total weight (t) | 483 | 98 | | | | | | |
| total weight incl. pushing truck (t) | - | - | | | | | | |
| transport route | - | | | | | | | |
| load | Rotor 19.24 x 7.80 x 7.15 385 t | | | | | | | |
| weight unit : tons (t) | | | | | | | | |
| Adam P. transpalux <small>route de Stavelot 124 L-9991 Weiswanpach</small> | vehicle combination | | | | | | | |
| | Selbstfahrer 12 x 2 Self propelled motor trailer | | | | | | | |
| | <table border="1"> <thead> <tr> <th>drawer</th> <th>Date</th> <th>Project / drawing-N°</th> </tr> </thead> <tbody> <tr> <td>Thelen</td> <td>03.09.08</td> <td>-</td> </tr> </tbody> </table> | drawer | Date | Project / drawing-N° | Thelen | 03.09.08 | - | |
| drawer | Date | Project / drawing-N° | | | | | | |
| Thelen | 03.09.08 | - | | | | | | |